

NG Fronthaul Network and Fog RAN

Tony Tam

Fujitsu Network Communications

10/26-28/2016

IEEE 1914.1 TF

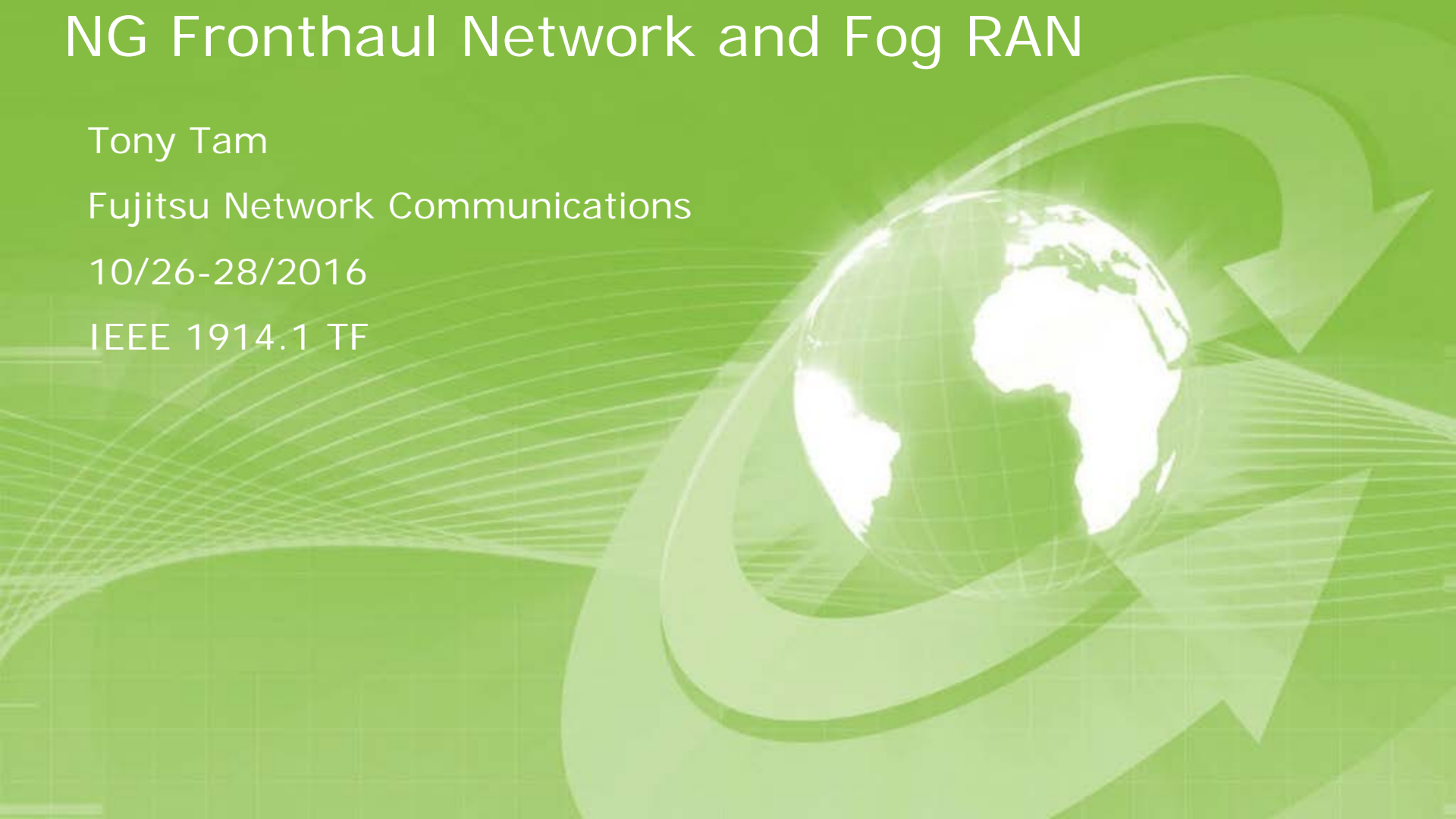

Compliance with IEEE Standards Policies and Procedures

Subclause 5.2.1 of the *IEEE-SA Standards Board Bylaws* states, "While participating in IEEE standards development activities, all participants...shall act in accordance with all applicable laws (nation-based and international), the IEEE Code of Ethics, and with IEEE Standards policies and procedures."

The contributor acknowledges and accepts that this contribution is subject to

- The IEEE Standards copyright policy as stated in the *IEEE-SA Standards Board Bylaws*, section 7, <http://standards.ieee.org/develop/policies/bylaws/sect6-7.html#7>, and the *IEEE-SA Standards Board Operations Manual*, section 6.1, <http://standards.ieee.org/develop/policies/opman/sect6.html>
- The IEEE Standards patent policy as stated in the *IEEE-SA Standards Board Bylaws*, section 6, <http://standards.ieee.org/guides/bylaws/sect6-7.html#6>, and the *IEEE-SA Standards Board Operations Manual*, section 6.3, <http://standards.ieee.org/develop/policies/opman/sect6.html>

IEEE 1914
Next Generation Fronthaul Interface
Jingri Huang, Huangjinri@chinamobile.com

NG Fronthaul Network and Fog RAN

Date: 2016-10-26 – 2016-10-28

Author(s):

Name	Affiliation	Phone [optional]	Email [optional]
Tony Tam	Fujitsu Network Communications		tony.tam@us.fujitsu.com

Agenda

- ❑ 5G Network Requirements and Challenges
- ❑ A holistic view of Each Challenge and Solutions
- ❑ 5G Network Challenges and Solutions

5G Network Requirements

Number of antennas More spectrum E.g. Mitigate interference

$$\text{Capacity} \approx n \cdot W \cdot \log_2 \left(1 + \frac{\text{Signal}}{\text{Noise}} \right)$$

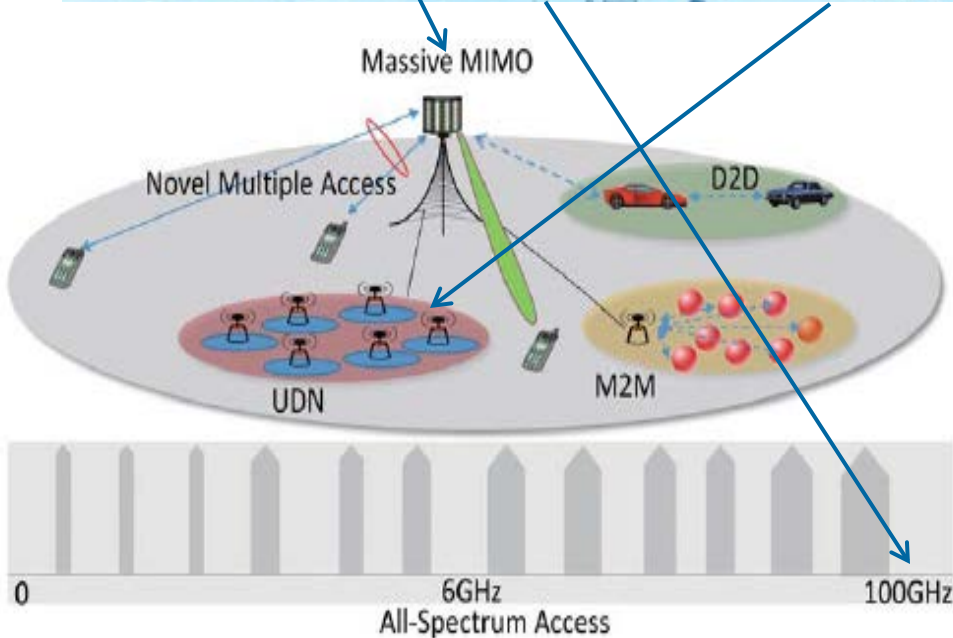

- Seamless wide-area coverage scenario
- High-capacity hot-spot scenario
- Low-latency high-reliability scenario
- Low-power massive-connections scenario

Main scenarios and suitable technologies for 5G

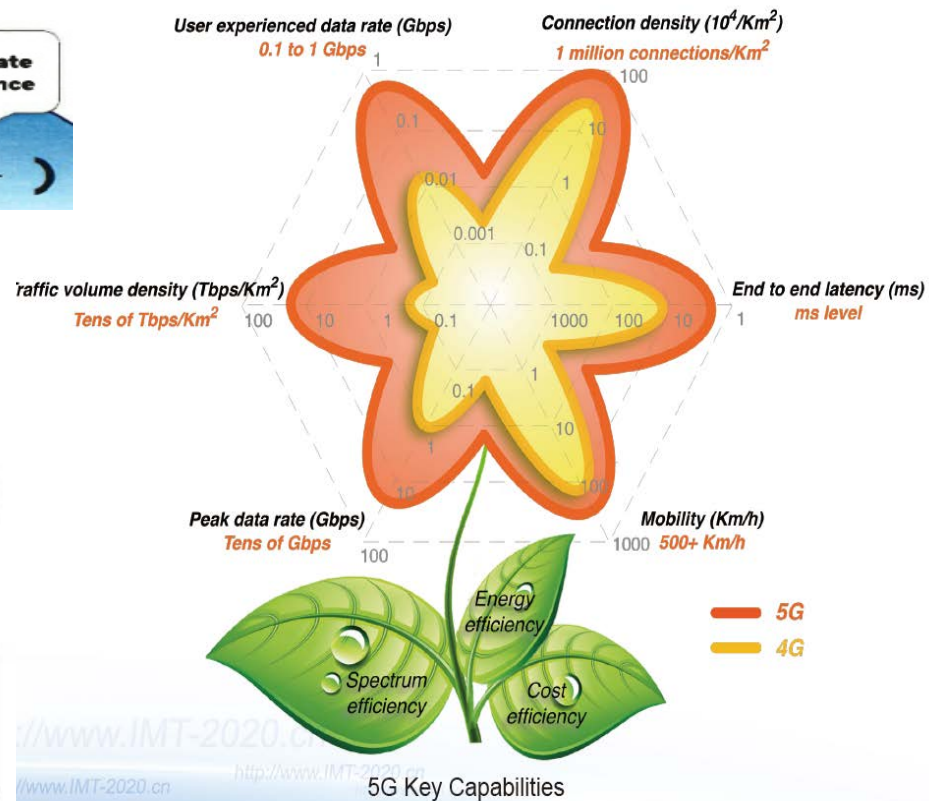

IMT 2020 5G Vision and Requirements
White Paper May 2014

5G Network Challenges

- ❑ 40x Fronthaul B.W. – 8xMIMO/20MHz -> 128xMIMO/100MHz
- ❑ Stringent E-2-E Delay 1ms – Vehicle and Tactile Internet
- ❑ Stringent RAN Delay – Interference Coordination in much denser network (<= 4ms)
- ❑ Mass Connection – 1M/km², a Smart Digital World & IoT Network Underlay
- ❑ Tremendous Traffic Volume Density – Tens of TB/km²
- ❑ Ultra-Reliable Network
- ❑ 5G KPIs - 1 or 2 order of magnitude over 4G, often opposite end of each other

xHaul Bandwidth Profiles & Solutions

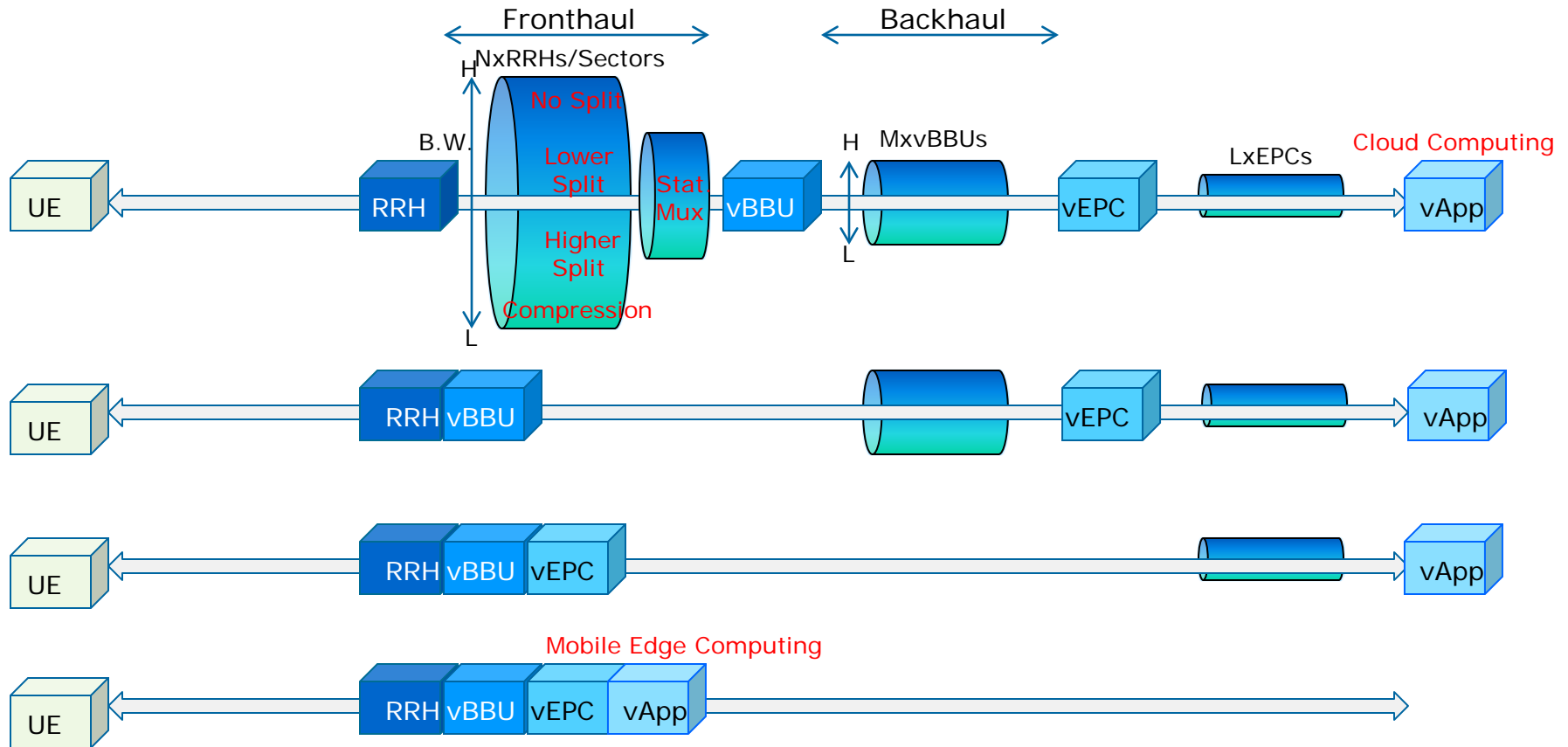

- ❑ FH the Higher the Split the Better, Compression & Stat. Muxing reduce it further
- ❑ BH B.W. lower than FH, the Earlier the Better
- ❑ Mobile Edge Computing reduce it to a minimum
- ❑ RAN Disaggregation – Keep RRH simple at L1 while virtualizing L2/3 & EPC & Apps

Interference Coordination Profiles & Solutions

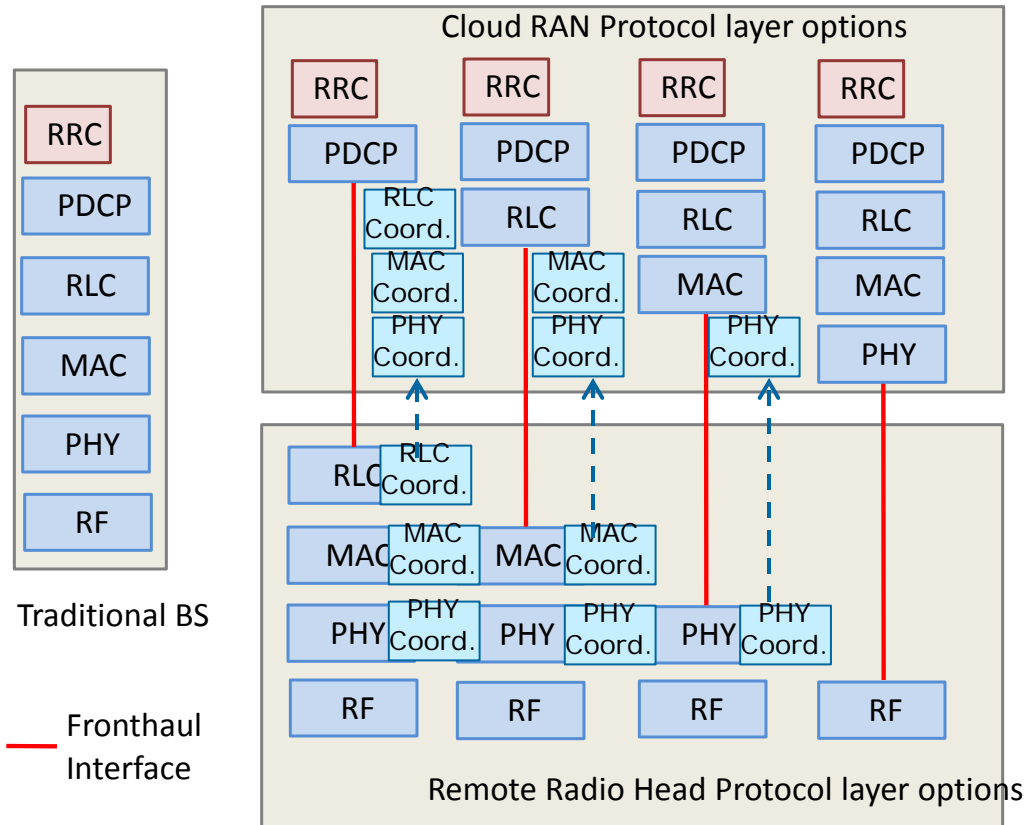

Traditional BS

— Fronthaul Interface

Remote Radio Head Protocol layer options

- ❑ The More Layers at the BBU, The Better The Coordination, The Worse The FH Load
- ❑ The Less Layers at the BBU, The Worse The Coordination, The Better the FH Load
- ❑ Process coordination locally(<4ms) & Global one at BBU – achieve the Best for Both
- ❑ Proposal to 3GPP via Liaison Letter

Stringent Delay

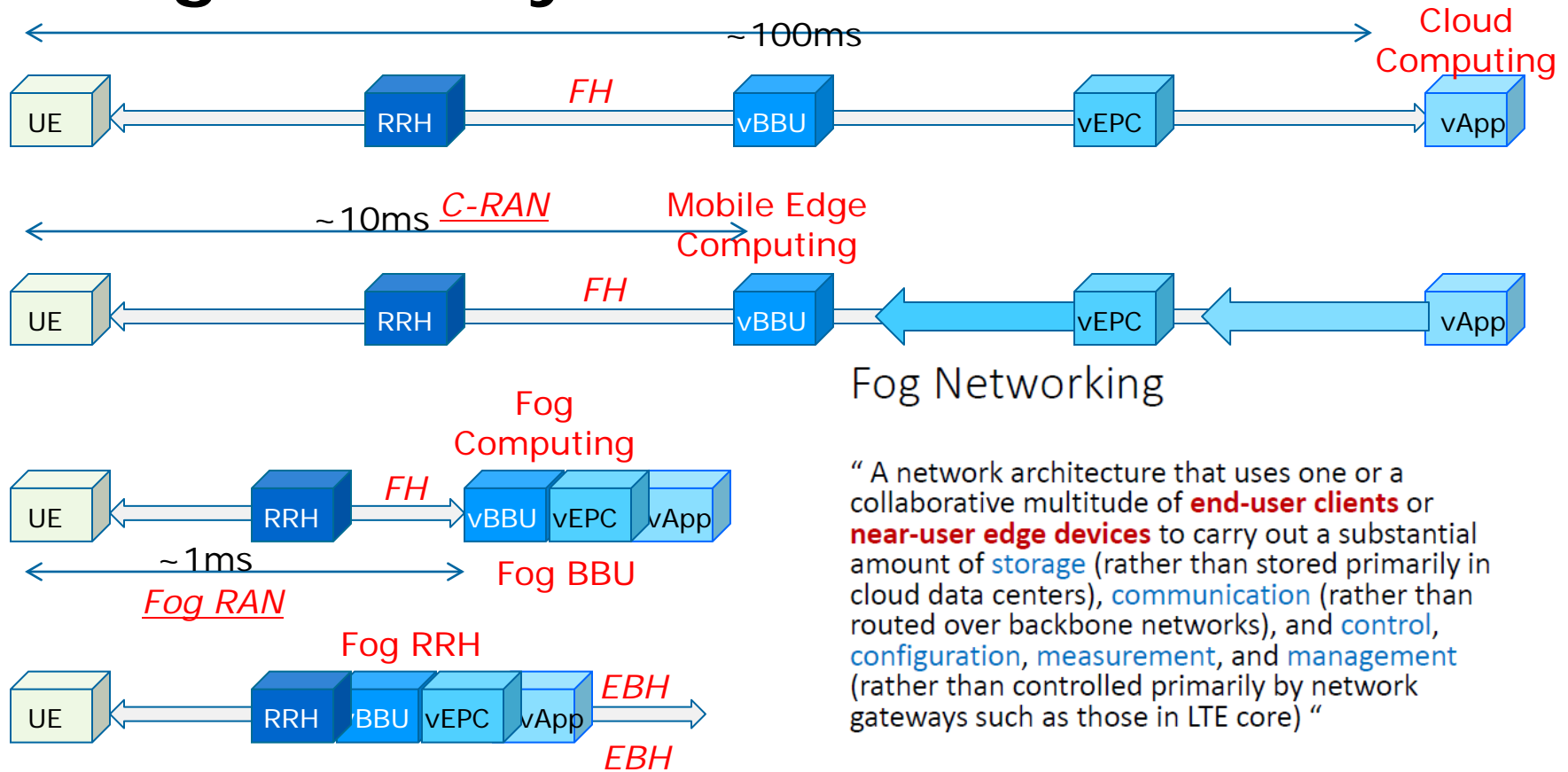

Fog Networking

“ A network architecture that uses one or a collaborative multitude of **end-user clients** or **near-user edge devices** to carry out a substantial amount of **storage** (rather than stored primarily in cloud data centers), **communication** (rather than routed over backbone networks), and **control, configuration, measurement, and management** (rather than controlled primarily by network gateways such as those in LTE core) “

Mung Chiang, Princeton University

IoT Network

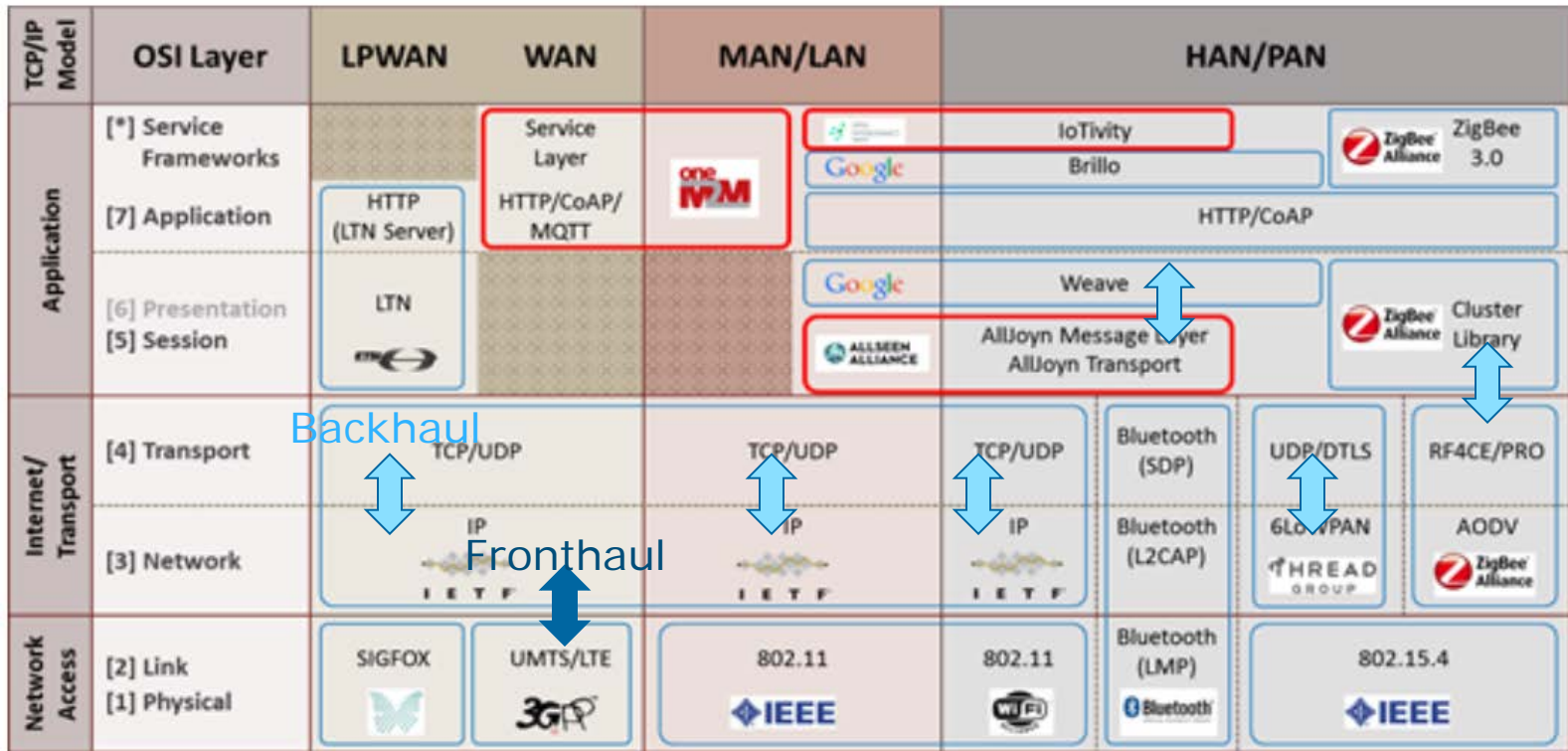

- ❑ IoT Networking either via 3GPP NB-IoT or standalone other means
- ❑ FH – 3GPP NB-IoT, BH – Other means
- ❑ IoT Gateway aggregates UE to minimize the mass connection to the FH/BH Network
- ❑ IoT Network Traffic – North-South and East-West

X-RAN & X-Haul Network

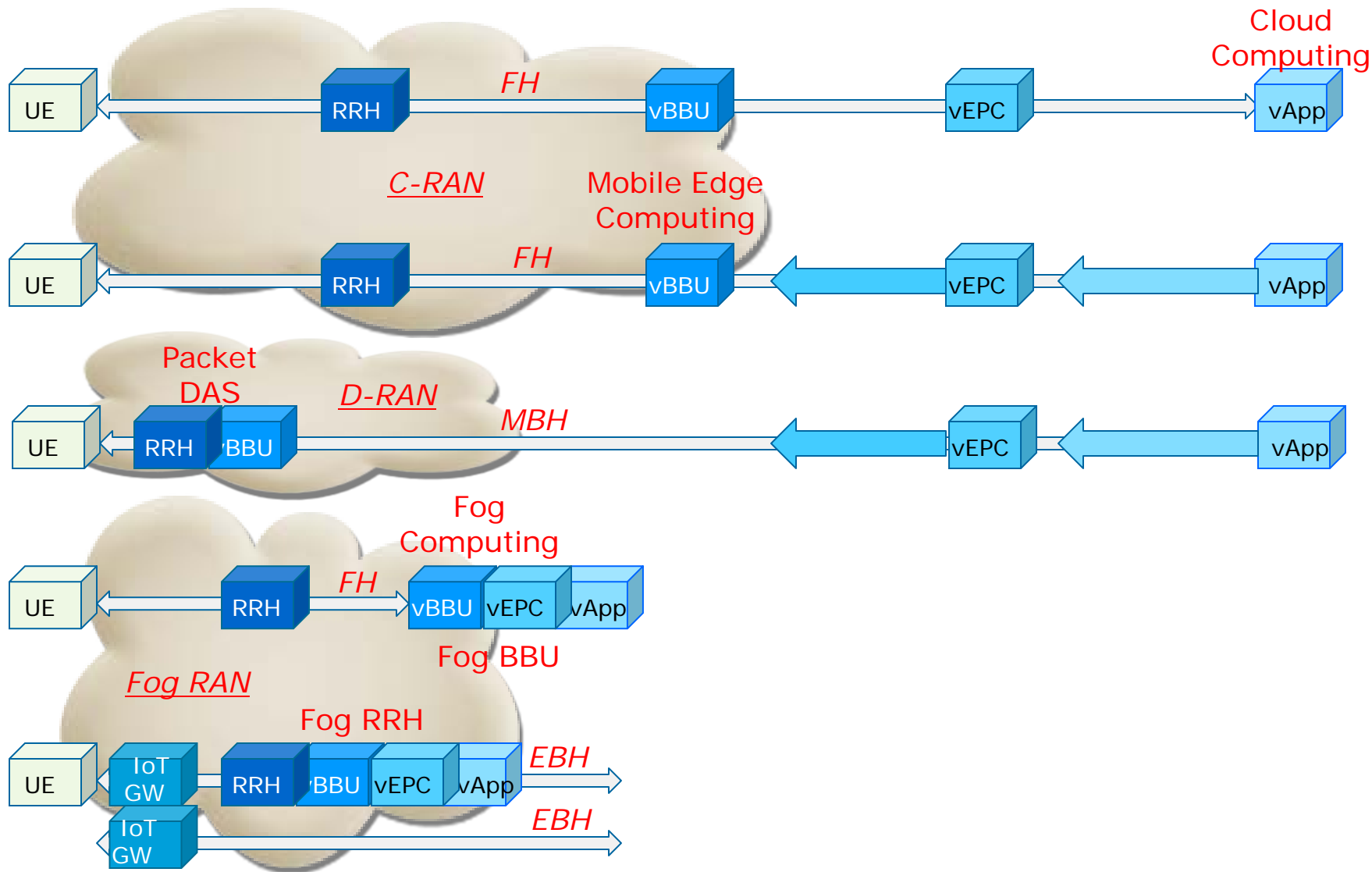

Ultra-Reliable Network

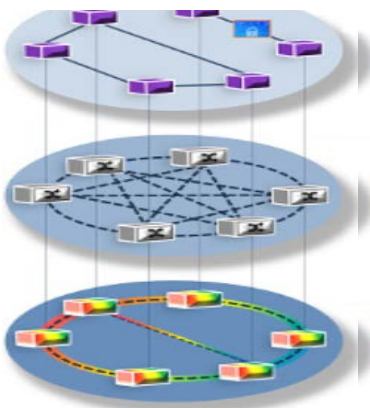
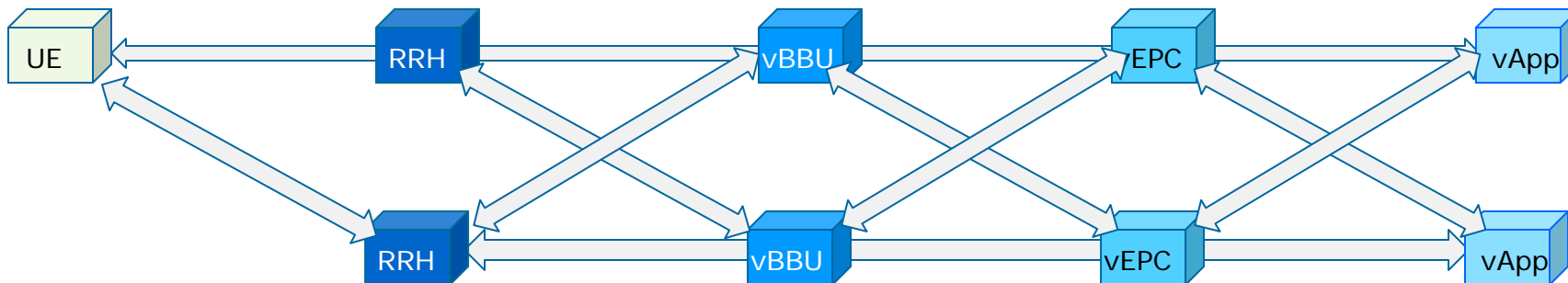

Aggregation

Packet

WDM

- Redundant Path at each Layer
- Ring and/or Path Protection Switching
- Network Rerouting
- Dual Homing
- Multi-Layer Protection and Restoration

5G Transport Network – Network Slicing

- ❑ Radio Frames ID visibility under SON Server Guidance
- ❑ Slices are assigned to V-LANs and Groups
- ❑ Each Slice can traverse different FH path
- ❑ Each Slice can traverse different BH path
- ❑ Protection Switching based on Each Slice
- ❑ Each Slice based on a distinct set of KPIs
- ❑ Each Slice varies across RF/FH/BH w/ Mobile Edge & Fog Computing options

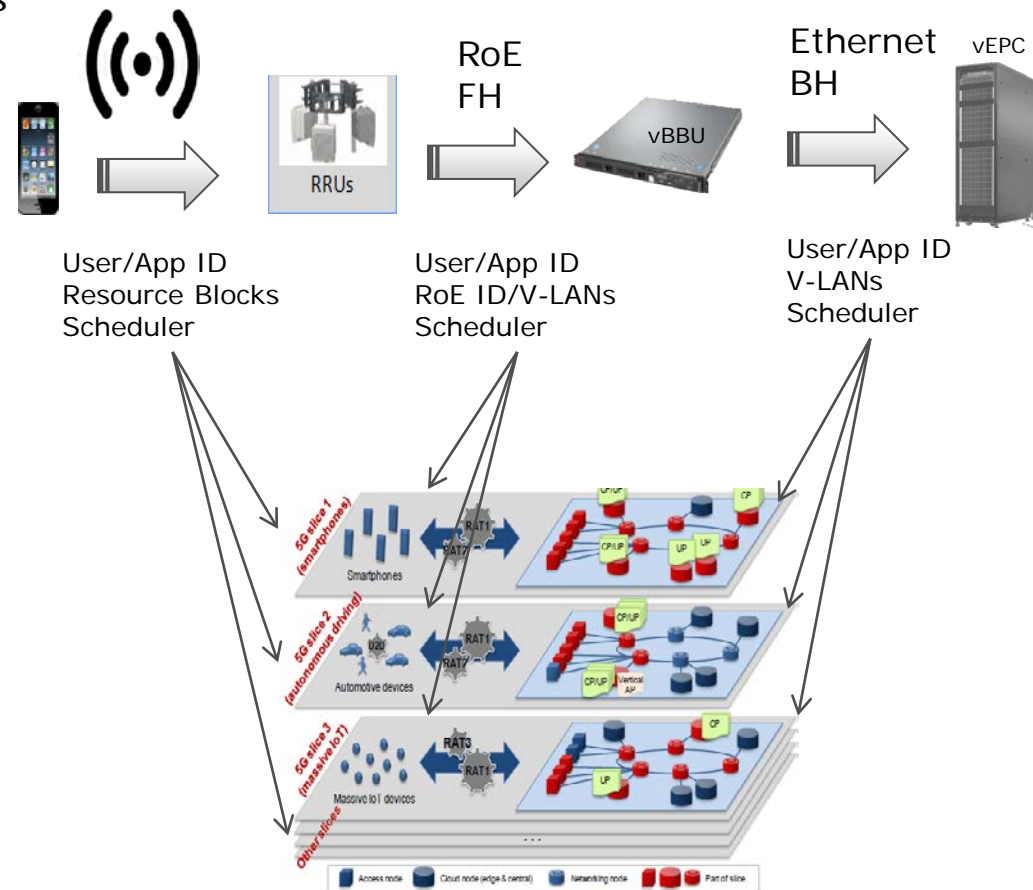

Figure 9: 5G network slices implemented on the same infrastructure

5G Network Challenges & Solutions

- ❑ 40x Fronthaul B.W. – 8xMIMO/20MHz -> 128xMIMO/100MHz
 - ❑ *Higher Functional Split/Compression/Stat. Muxing*
- ❑ Stringent E-2-E Delay 1ms – Vehicle and Tactile Internet
 - ❑ *Mobile Edge & Fog Computing*
- ❑ Stringent RAN Delay – Interference Coordination in much denser network (≤ 4 ms)
 - ❑ *Process coordination locally & add global one at BBU while allowing higher functional split*
- ❑ Mass Connection – 1M/km², a Smart Digital World & IoT Network Underlay
 - ❑ *IoT Gateway and Network underlay*
- ❑ Tremendous Traffic Volume Density – Tens of TB/km²
 - ❑ *Mobile Edge & Fog Computing*
- ❑ Ultra-Reliable Network
 - ❑ *Redundancy at every layer and Junction*
- ❑ 5G KPIs - 1 or 2 order of magnitude over 4G, often opposite end of each other
 - ❑ *Network Slicing based on KPIs*
- ❑ *A New Paradigm – X-RAN and X-Haul Network*

Motion #_

- Agree as the high level framework for the NG Fronthaul Network Requirements and Architecture
- Mover: Tony Tam
- Seconder:
- Yes: ____, No: ____, Abstain: ____ (technical motion needs $\geq 2/3$)