

Fronthaul scenarios and
1914 transport classes

Vincenzo Sestito, SM Optics
June 22nd, 2017



Compliance with IEEE Standards Policies and Procedures

Subclause 5.2.1 of the *IEEE-SA Standards Board Bylaws* states, "While participating in IEEE standards development activities, all participants...shall act in accordance with all applicable laws (nation-based and international), the IEEE Code of Ethics, and with IEEE Standards policies and procedures."

The contributor acknowledges and accepts that this contribution is subject to

- The IEEE Standards copyright policy as stated in the *IEEE-SA Standards Board Bylaws*, section 7, <http://standards.ieee.org/develop/policies/bylaws/sect6-7.html#7>, and the *IEEE-SA Standards Board Operations Manual*, section 6.1, <http://standards.ieee.org/develop/policies/opman/sect6.html>
- The IEEE Standards patent policy as stated in the *IEEE-SA Standards Board Bylaws*, section 6, <http://standards.ieee.org/guides/bylaws/sect6-7.html#6>, and the *IEEE-SA Standards Board Operations Manual*, section 6.3, <http://standards.ieee.org/develop/policies/opman/sect6.html>

IEEE 1914
Next Generation Fronthaul Interface
Jinri Huang, huangjinri@chinamobile.com

Fronthaul scenarios and
1914 transport classes

Date: 2017-06-22

Author(s):

Name	Affiliation	Phone [optional]	Email [optional]
Vincenzo Sestito	SM Optics		vincenzo.sestito@sm-optics.com

Premises

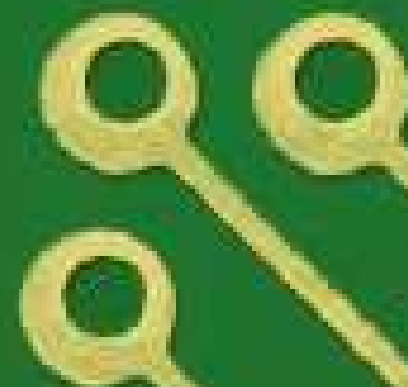

1914 - Converged RAN view and split points

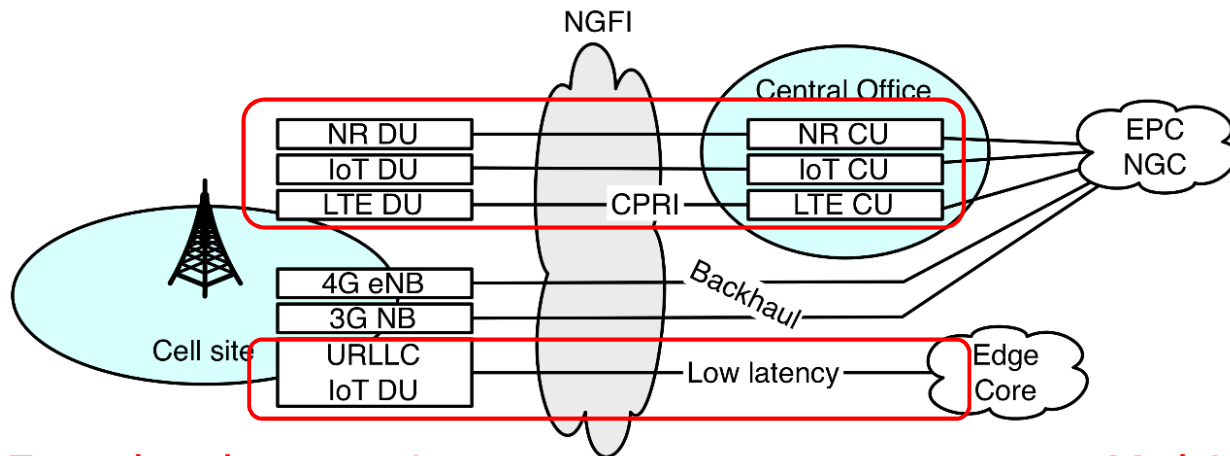

Fronthaul scenarios

Multiple splits over network

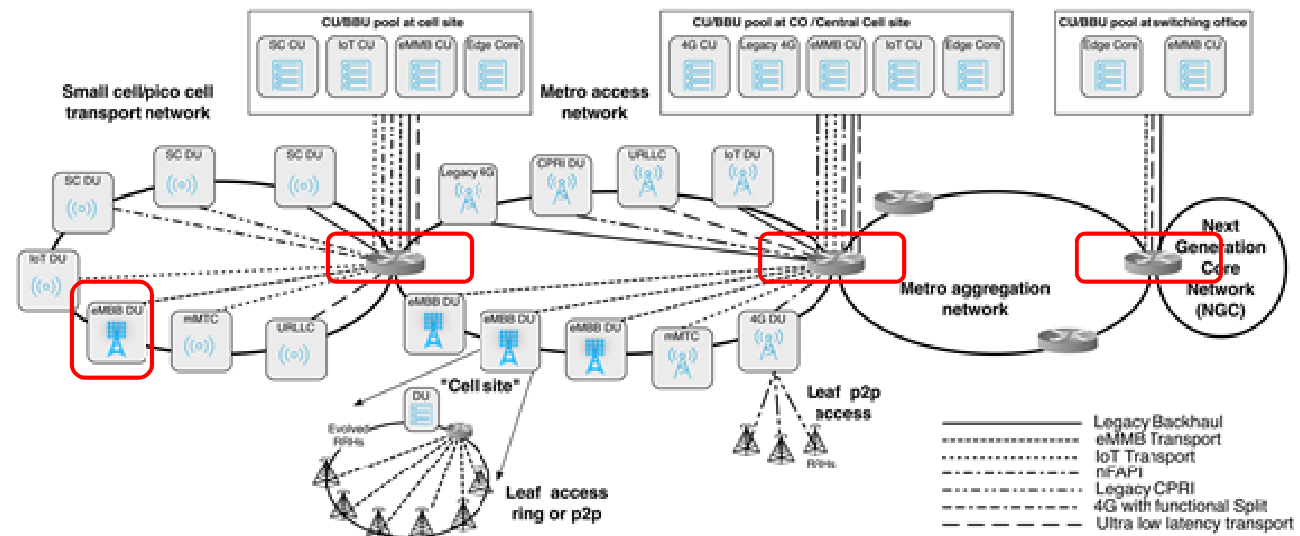

Source: IEEE 1914.1 D0.2

3GPP Functional Split Options

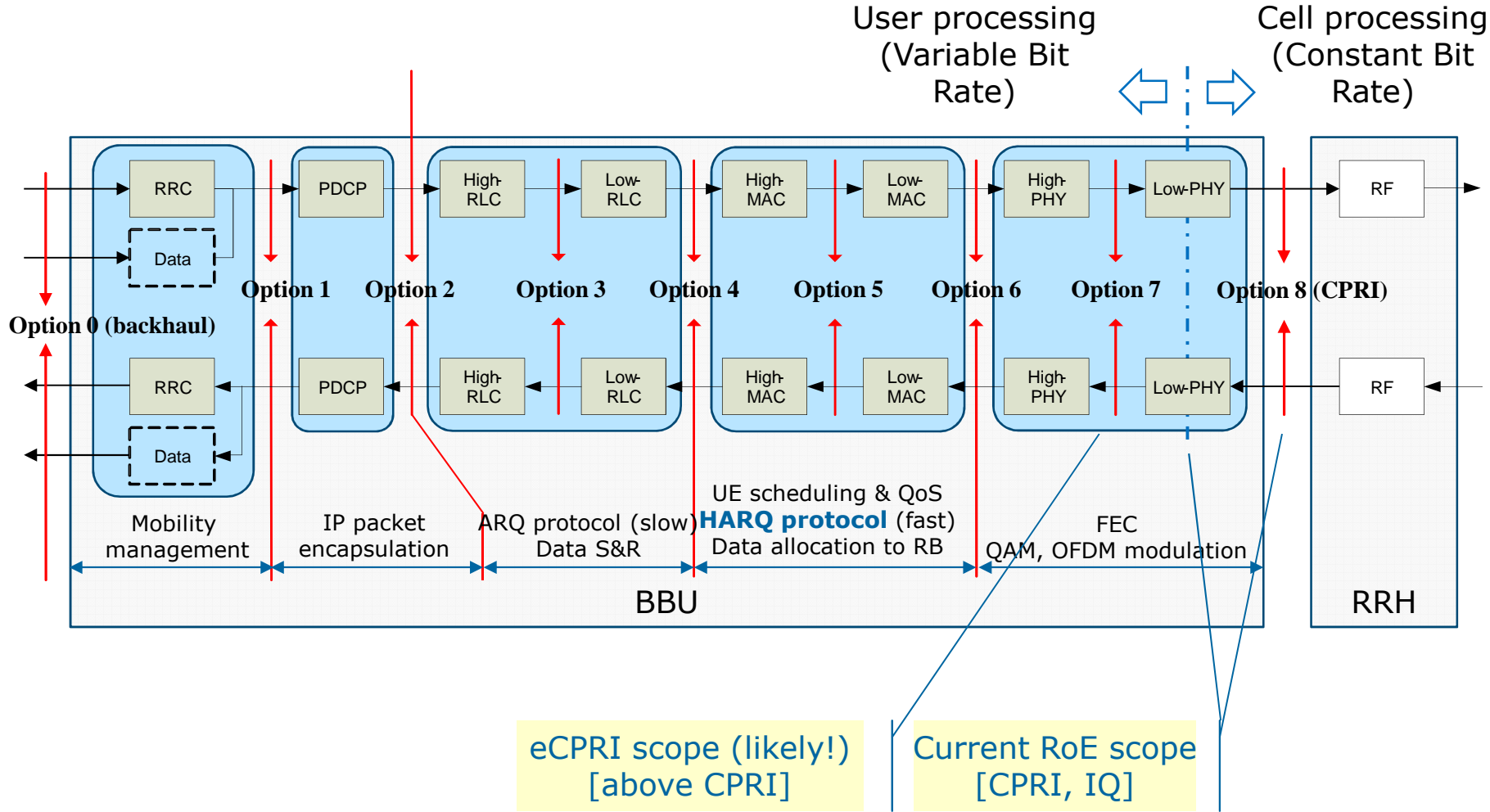

Two levels FH network

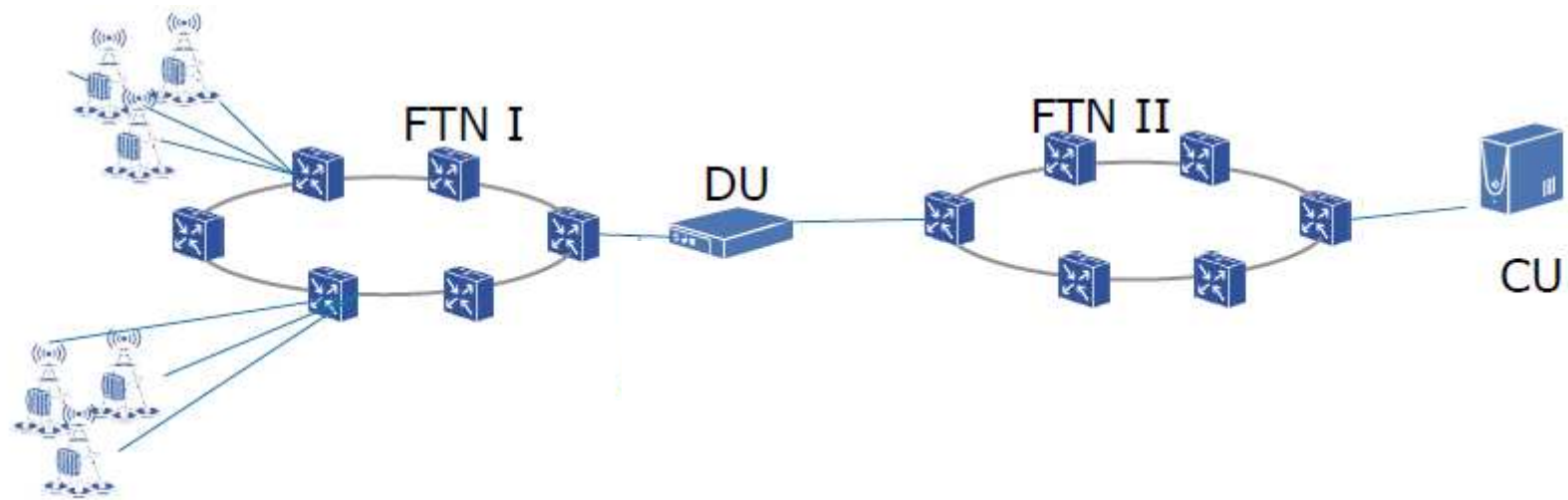

Source: CMCC contribution to 1914 WG meeting in Beijing

Latency requirements – LTE and 5G fronthaul

LTE-A Backhaul reference [TR 36 912 V9.0.0]

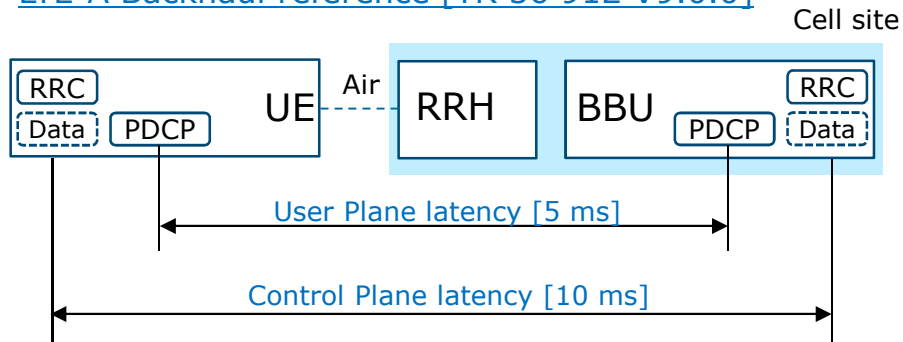

5G User plane latency [38913] - The time it takes to successfully deliver an application layer packet/message from the radio protocol layer 2/3 SDU ingress point to the radio protocol layer 2/3 SDU egress point via the radio interface in both uplink and downlink directions, where neither device nor Base Station reception is restricted by DRX (Discontinuous Reception occurring when in Idle mode for accomplishing with “paging” process).

5G Control plane latency [38913] - Control plane latency refers to the time to move from a battery efficient state (e.g., IDLE) to start of continuous data transfer (e.g., ACTIVE).

5G Fronthaul reference [TR 38913]

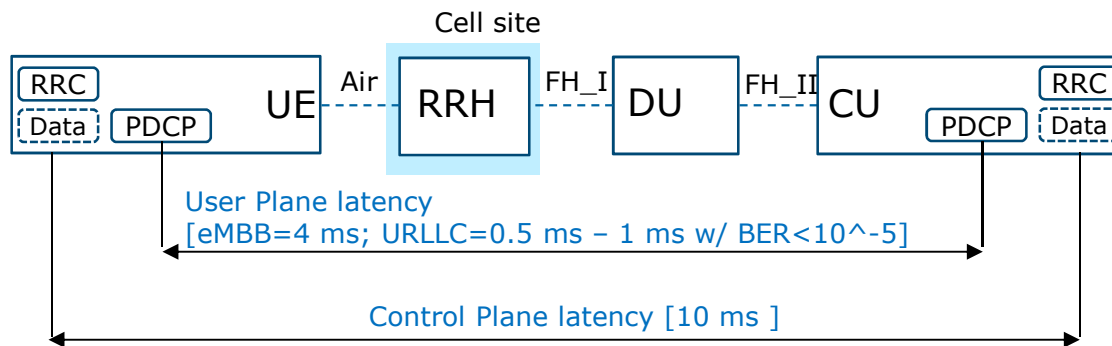

FH_I: fronthaul network stage I
FH_II: frontahul network stage II

Note - Latency requirements considered here refer to UE/eNb scope and do not include connectivity towards Core elements

NGFI transport classes of service

Class	Sub Class	Priority Level	Latency upper bound requirement (one way)	Throughput requirement (10%)	Reliability	Reserved	informative
control & management	synchronization	TBD	TBD				
	RAN control-plane	2	τ_1				
data-plane	Subclass_0	0	τ_0		Yes		URLLC Application
	Subclass_1	1	τ_1				3GPP model Option 6,7,8
	Subclass_2	2	τ_2				3GPP model Option 2,3,4,5
	Subclass_3	3	τ_3				Legacy backhaul
Transport NW control & management	Transport NW control-plane	2	τ_2				
Reserved							

	τ_0	τ_1	τ_2	τ_3
Profile 1	50 μ s	100 μ s	1ms	10ms

$$\tau_0 \leq \tau_1 \leq \tau_2 \leq \tau_3$$

Source: AT&T contribution to 1914 WG meeting in Dallas

FH scenarios and traffic classes

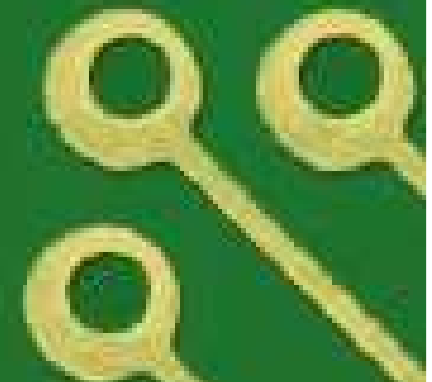

Legacy FH – CPRI (LTE and former services)

- In this scenario, CPRI (split option 8) is assumed to be the signal format provided by the antenna link.
- This scenario applies to LTE (and former) services and it might apply to eMBB (5G), at least, for transitory phase towards different split option/interface.
- It is unlikely that CPRI can also support remaining 5G services, mMTC and URLLC: since recently defined, it is expected that related antenna elements/ sensors provide a packet based signal.
- Legacy FH, CPRI based, relies commonly on a single split: an aggregator of RRH's signals is placed at cell site and remaining blocks of BBU are placed in a single CU site. However, a double split may apply, provided to include at least MAC layer (devoted to HARQ handling) on the first available edge of fronthaul network (CU_A in the following example, but, in principle also DU may have this role) and to locate higher layer blocks in a farer CU stage. DU may be dedicated per cell site (then, co-located) or shared among more sites (then, located in different place).
- Both in single/double split scenario, fronthaul network is expected to cope with 1914 subclass 1, up to the edge where MAC layer is implemented (i.e., FH_I and FH_II, in the following example).
- In case of double split, the further stage of fronthaul network (FH_III, in the example) may comply to subclasses 2 or 3 depending on the actual layer implemented at CU_A and CU_B.

Legacy FH – CPRI – (LTE and former services)

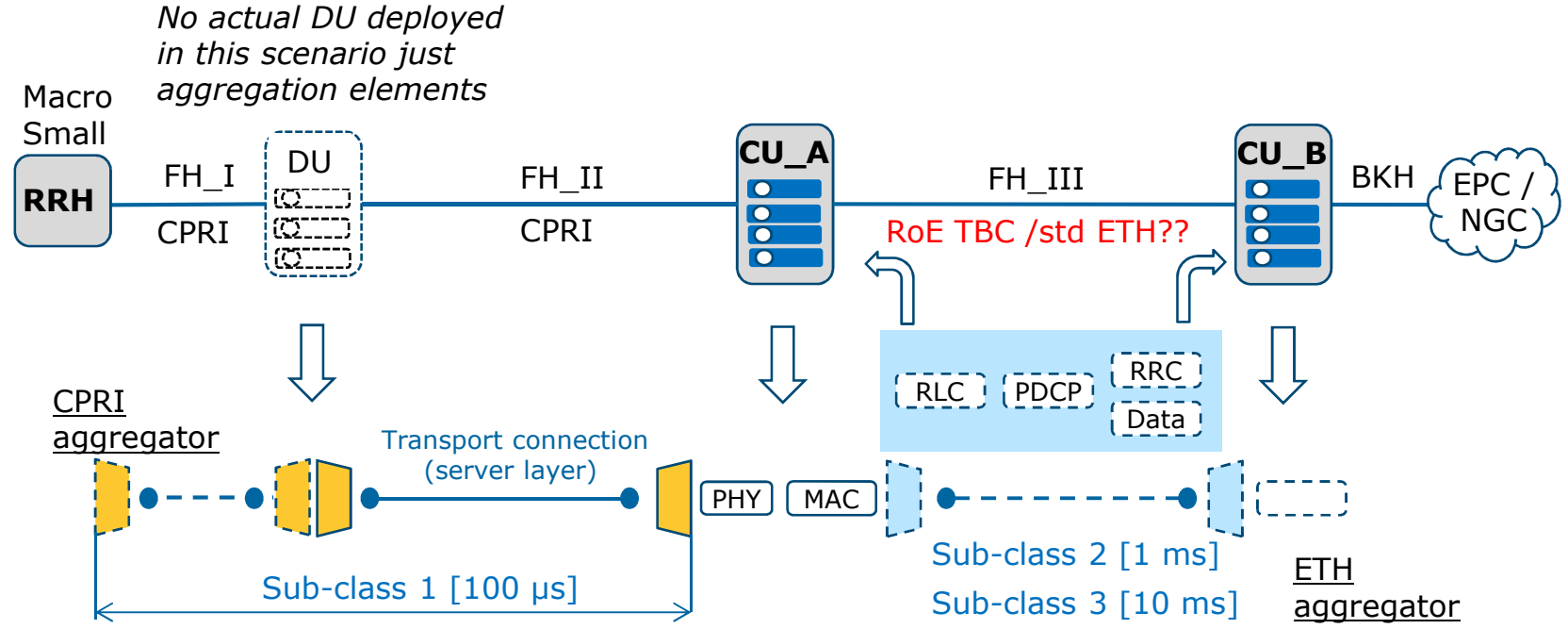

- BS/eNB blocks
- L1 client aggregation blocks
- L2 client aggregation blocks
- Transport connection (Lx-server layer, x=0, 1, 2)

NG_FH – CPRIoETH (LTE and 5G enabling)

- In this scenario, legacy CPRI sourced by RRH's is encapsulated in RoE packet: DU realizes, in this case the mapping procedure/RRH's signal aggregation and possibly the functional split toward CU.
- As for legacy CPRI scenario, DU may or may not be co-located with RRH's, depending on the network application.
- In case of mapping over ETH (RoE) performed close to cell sites, the network scheme recalls the legacy CPRI splits possibilities: CU_A may include all of the functional blocks; so as, in alternative, it may just hosts PHY+MAC layers (at least, for HARQ termination) leaving the remaining blocks at CU_B.
- In case of higher layers at DU, including MAC block (option 5), would result in keeping tight latency requirements just in the scope of FH_I connectivity [Note](#).

[Note - TR38913 suggests ISD= 5 Km for rural applications, thus FH_I scope <10 Km.](#)

This implies that CU_A centralizes either fully or partially remaining processing blocks. In this last case, a further CU_B stage may be considered: sub-class 2 characterizes the transport network FH_II; while sub-class 3 may be applied to FH_III transport connectivity.

- It has to be noticed that just PHY block (options 7, 6) might be included in DU processing resulting in sub-class 1 requirement to be applied up to FH_II. FH_III would then rely on sub-classes 2, 3.

NG_FH – CPRIoETH (LTE and 5G enabling)

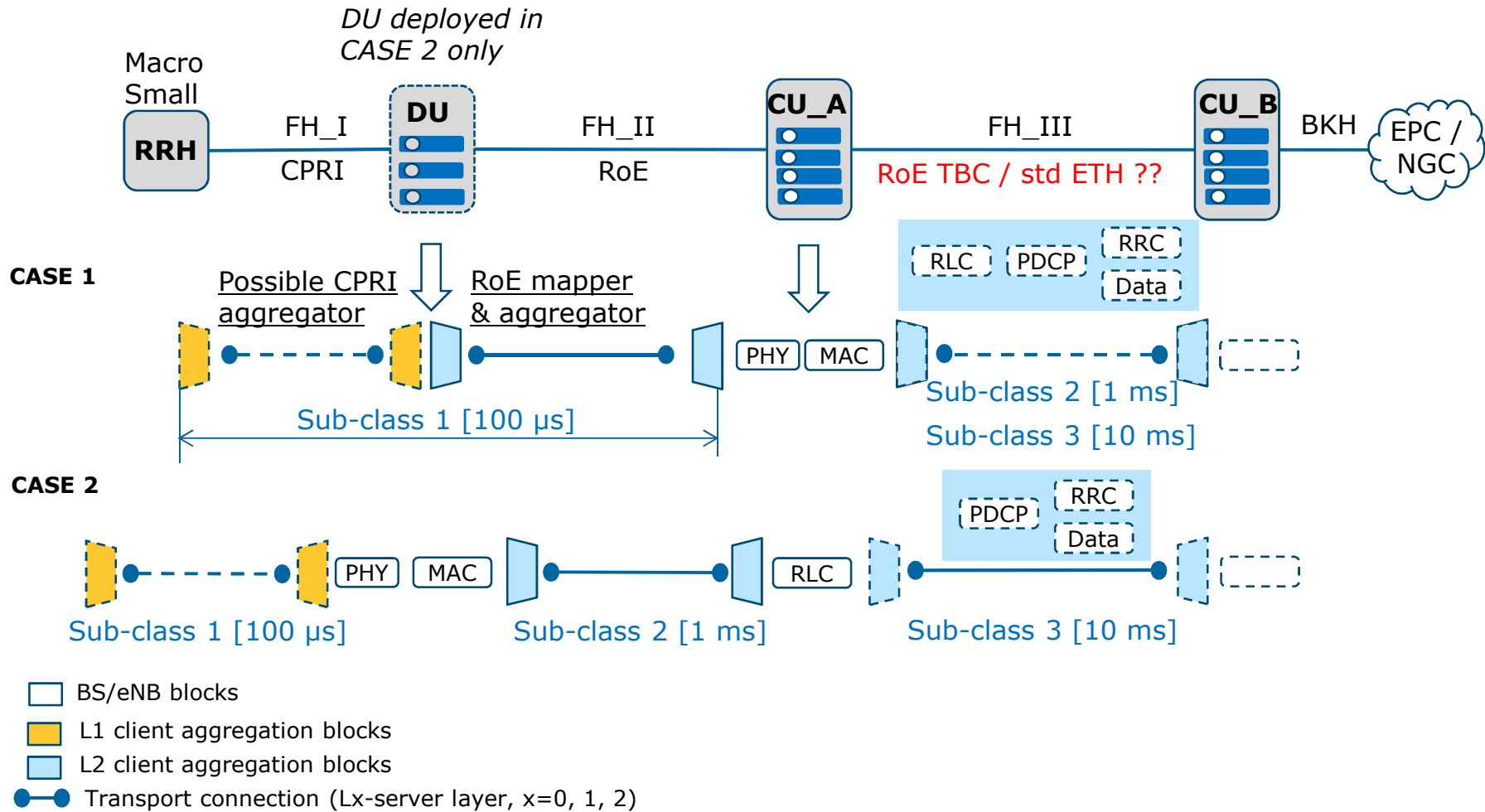

NG_FH – RoE (eMBB and mMTC)

- In this scenario, RoE (or eCPRI) is assumed to be the signal format provided by the antenna link: this implies that PHY block is partially or, in principle, totally integrated into RRH, with different flavours possibly [Note](#) compliant to split options 7 and 6.
[Note – 1914 currently supports option 8 and I/Q native mapping - eCPRI is likely positioned somewhere in PHY block, so option 7 compliant.](#)
- This scenario applies to 5G services, due to the assumed transmission of antenna signals in packet format.
- In case of no split performed close to cell sites, blocks higher than PHY (or PHY') are integrated into CU. An ETH aggregator grooms signals coming from cell site(s): transport solution sub-class 1 applies to the network between RRH's and CU, where HARQ (or equivalent 5G protocol) is terminated.
- In case of split at DU, as per «CPRIoETH» scenario, the integration of MAC (or layer terminating equivalent HARQ protocol) would keep the latency constraint between RRH and DU. While sub-classes 2 or 3 may apply to FH_II and FH_III depending on the actual split operated at CU_A and CU_B.

NG_FH – RoE (eMBB and mMTC)

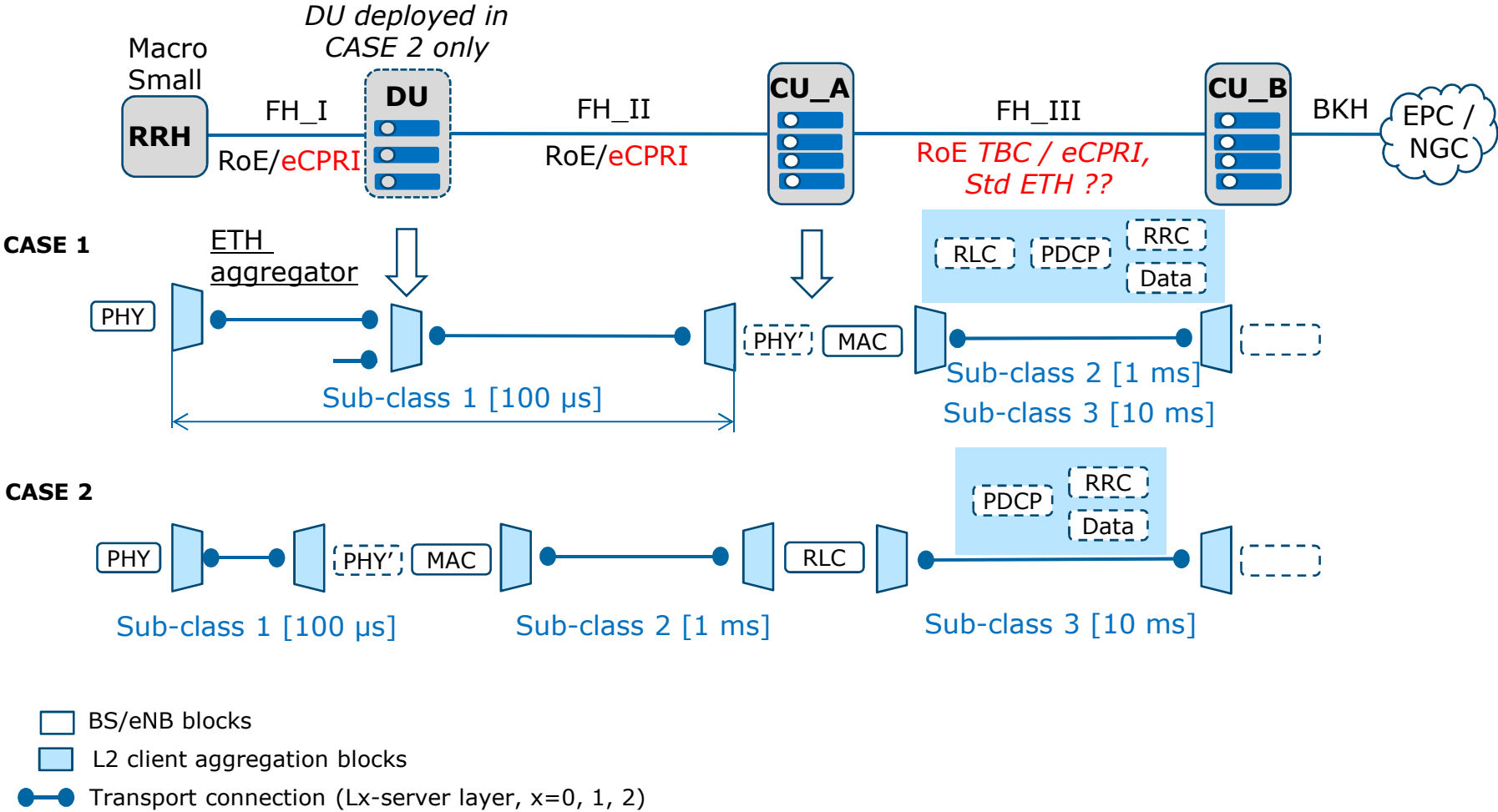

NG_FH – RoE (URLLC, mMTC)

- Most critical services for latency requirement (URLLC and mMTC) need very likely a Controller location closer to the radio elements, than the one for eMBB or mMTC (relaxed performance): this implies the usage of different CU's.
- User Plane latency requirement derived from 3GPP (0.5/1 ms for URLLC) results in sub-class 0 application.
- In case of no split close to cell site, keeping all the BBU blocks devoted to critical services at CU should give more chances for resource sharing.
- Possible split at DU may apply, depending on the actual termination of time sensitive protocols (HARQ-like). This may give more margin to the network span DU-CU (FH_II), with respect to the total 50 μ s latency budget. However, no «multiple split» is likely in this scenario due to the tight UP latency requirement.

NG_FH – RoE (URLLC, mMTC)

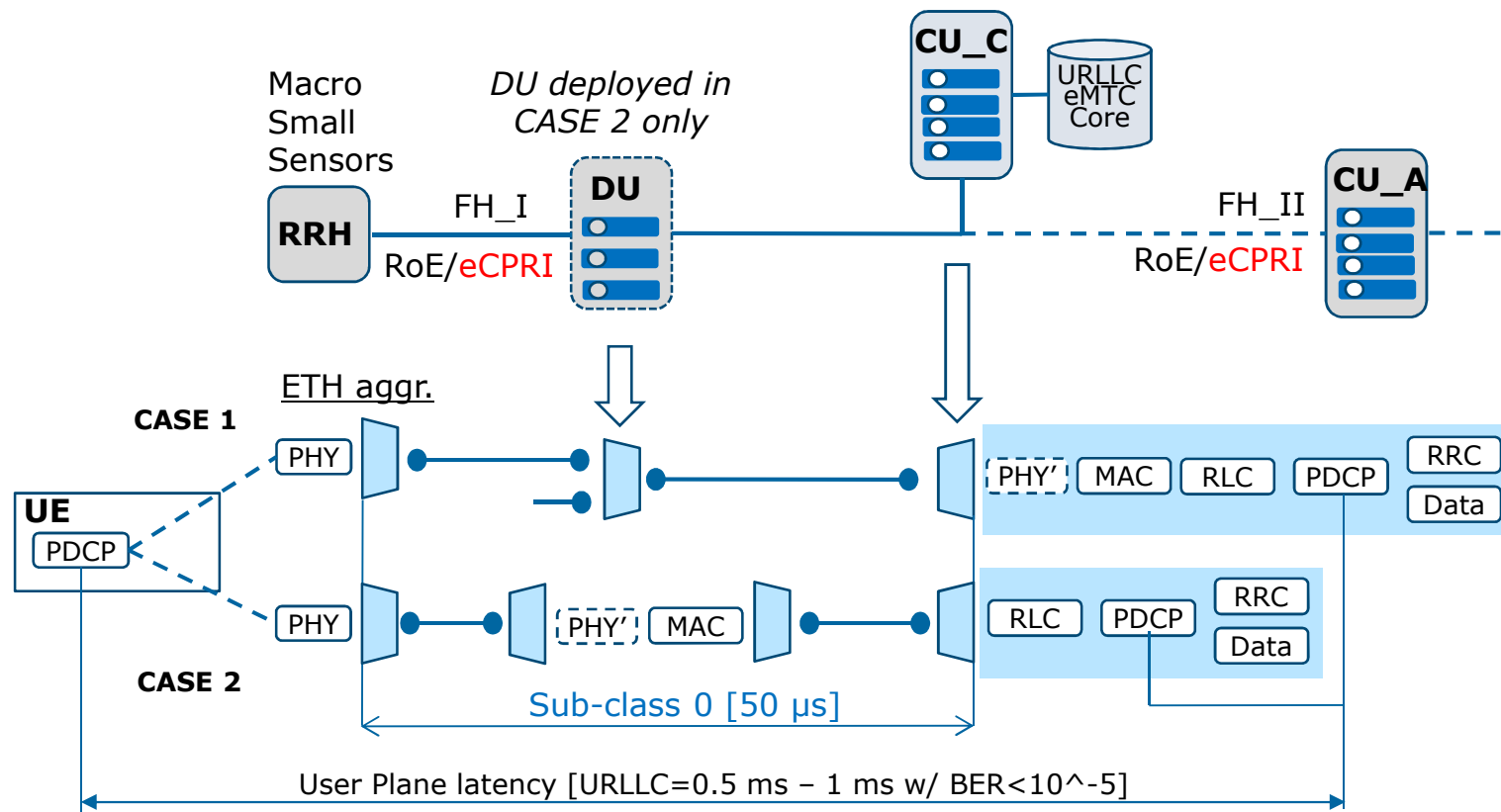

- BS/eNB blocks
- L2 client aggregation blocks
- Transport connection (L_x-server layer, x=0, 1, 2)

Transport connection

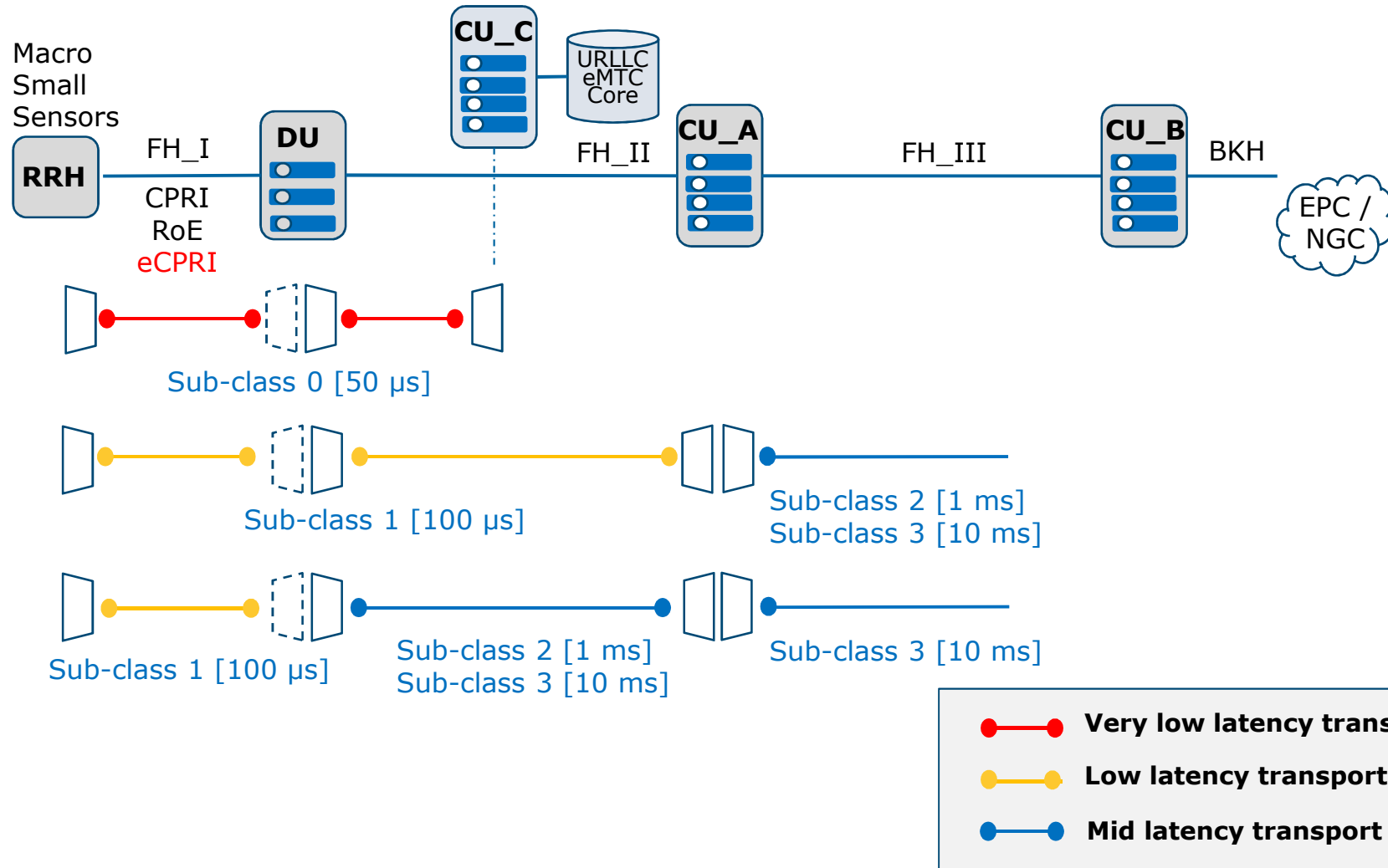

Transport connection

- ❖ [Fulfilment of sub-class 0](#) implies the application of a single split across the FH network, and, very limited (or no) switching elements in the connection RRH-CU, depending also on the the actual optical links length. Due to the tight requirement in latency (and jitter), it also drives to the extensive application of the lowest layer technology available (L0).
- ❖ [Fulfilment of sub-class 1](#) may allow multiple split across the network, provided to keep the layer handling time sensitive protocols (e.g. HARQ) as close as possible to the cell site.

The requirements (latency/jitter) are expected to be compatible with both L1 and L2 mapping and networking (e.g., ETH RoE, ETH TSN/CM, OTN) where a controlled engineering of the network (geographical scope, span length, amount of switching nodes) is realized.

Additional deployment of L0 technologies (e.g., WDM) may occur for optimizing the usage of transmission resources.

- ❖ [Fulfilment of sub-classes 2 and 3](#), implies more relaxed latency/jitter requirements, meaning higher span length length and more switching elements across the network.

The requirements allows for both L1 and L2 mapping and networking.

Additional deployment of L0 technologies (e.g., WDM) may occur for optimizing the usage of transmission resources.

Further steps proposed

Consolidating previous assumptions by providing a view on path latency performances (RRH-CU) associated to different transport options and realistic mix of traffic over the network:

- ROE (CPRI/IQ) over ETH TSN/CM (& WDM)
- ROE (CPRI/IQ) over OTN (& WDM)
- ROE (CPRI/IQ) over radio

....other options?????

THANK YOU!